

Mechanical In-Line Repair
Sleeves with Moisture/
Contaminant Block for
Medium/High Voltages

MECHANICAL CONNECTORS

'USMFx/RS' Aluminium Repair Sleeves



Principle Application:

Straight in-line splicing of damaged cable cores, suitable for use on stranded aluminium/copper cored cables.

Range:

Connector Reference (Part Number)	Stranded Core Size			
	Min	Max	Min	Max
USMF1/RS (51811-56)	# 2 (34mm ²)	250 kcmil (127mm ²)	# 2 (34mm ²)	250 kcmil (127mm ²)
USMF2/RS (51811-57)	1/0 (67mm ²)	500 kcmil (253mm ²)	1/0 (67mm ²)	500 kcmil (253mm ²)
USMF3/RS (51811-58)	500 kcmil (253mm ²)	1000 kcmil (507mm ²)	500 kcmil (253mm ²)	1000 kcmil (507mm ²)
USMF7/RS (51811-59)	350 kcmil (177mm ²)	750 kcmil (380mm ²)	350 kcmil (177mm ²)	750 kcmil (380mm ²)

The '**USMFx/RS**' range of mechanical connectors incorporate an integral moisture/contaminant block and utilise the patented universal range taking shear bolts. (USA Patent No's 6209424 & 6321624)

The appropriate socket is to be used at all times, typical examples shown below.



'JTS/9' 1/2" sq Driver

Mechanical In-Line Repair
Sleeves with Moisture/
Contaminant Block for
Medium/High Voltages

‘USMFx/RS’ Aluminium Repair Sleeves

Physical Dimensions:

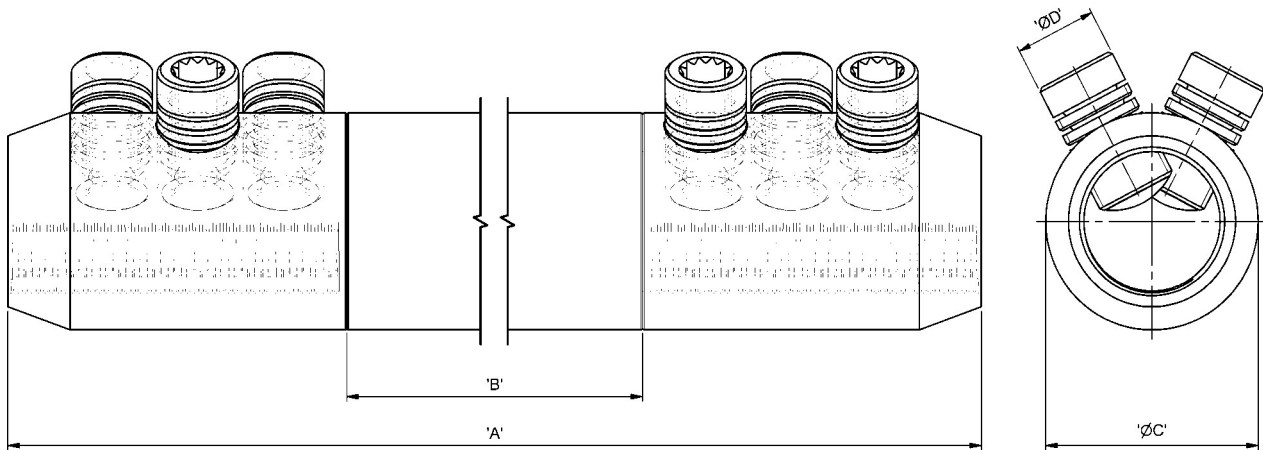

Connector Reference (Part Number)	Dimensions			
	‘A’	‘B’	‘ØC’	‘ØD’
USMF1/RS (51811-56)	17.91” (455mm)	14.13” (359mm)	1.10” (28mm)	M16
USMF2/RS (51811-57)	17.91” (455mm)	13.74” (349mm)	1.34” (34mm)	M16
USMF3/RS (51811-58)	17.91” (455mm)	12” (305mm)	1.85” (47mm)	M18
USMF7/RS (51811-59)	15.00” (381mm)	10” (254mm)	1.48” (37.5mm)	M18

Material: Aluminium Alloy (Electro-Tinned)

Test Specification: ANSI C119.4 Class 2 Partial Tension

Test Report No: TTR/271 & TTR/272

Fitting instructions:

1. Strip insulation from each core equal to the depth of the bore.
2. Wire brush the exposed conductor cores and wipe clean (optional).
3. Align and position the conductor cores in each of the bores ensuring that the core is fully inserted to the centre wall.
4. Fit the universal shear screws within the connector and torque tighten one turn at a time, using the correct socket, until the bolts have sheared.