

**MF4 Hybrid Connectors
- Heat Shrink Section**



Principle Application:

Stranded and solid shaped service conductors.

Range:

Product Reference (Part Number)	Type	Core C.S.A. (mm ²)	
		Min	Max
MF4/24 (2466-317)	Straight Through	6*	16
MF4/25 (2466-318)	Moisture Blocked	6*	16

Note: For jointing other core configurations/sizes please contact Sicame Engineering Dept

The **Sicame MF4** hybrid range of mechanical connectors are designed for straight connections on stranded or solid service cables. The aluminium connector yoke is electro-tinned as standard and is supplied with brass grub screws making it suitable for jointing copper/aluminium, sector/circular shaped conductors.

This particular range of mechanical ferrules have been specifically designed for joints where a cold or heat shrink sleeving is a requirement.

**MF4 Hybrid Connectors
- Heat Shrink Section**

Secondary Application:

Stranded and solid circular conductors.

Range:

Product Reference (Part Number)	Type	Maximum Core C.S.A. (mm ²)	
		Solid	Stranded
MF4/24 (2466-317)	Straight Through	35	35
MF4/25 (2466-318)	Moisture Blocked	35	35

* Note: Conductors below 6mm² should be doubled and, if necessary, doubled again to achieve a satisfactory cross sectional area.

Physical Dimensions:

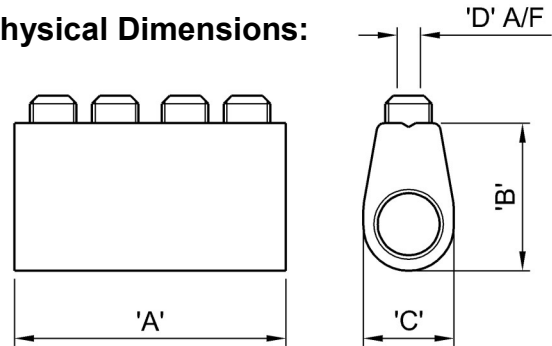

Product Reference (Part Number)	Dimensions (mm)			
	'A'	'B'	'C'	'D'
MF4/24 (2466-317)	35.0	19.0	11.7	3.0
MF4/25 (2466-318)	44.0	19.0	11.7	3.0

Material:

Body: Aluminium Alloy (Tinned)

Screws: Brass

Test Specification:

BS EN 61238-1 : 2003 Compression and Mechanical Connectors for power cables for rated voltages up to 36 kV. Test Methods and Requirements.

Test report numbers - TTR/320, TTR/321, TTR/324, TTR/325, TTR/331, TTR/333

Fitting Instructions:

1. Strip the core insulation equal to the length of the connector + 3mm.
2. Thoroughly abrade and clean all conductors to be joined.
3. Align cores within connector and tighten screws on each side of the connector consecutively, until tight.

Note: * Conductor cores 4mm² and below should be doubled, and if necessary doubled again, to achieve the necessary cross-sectional area.