

US1, US2, US3 & US4 Connectors

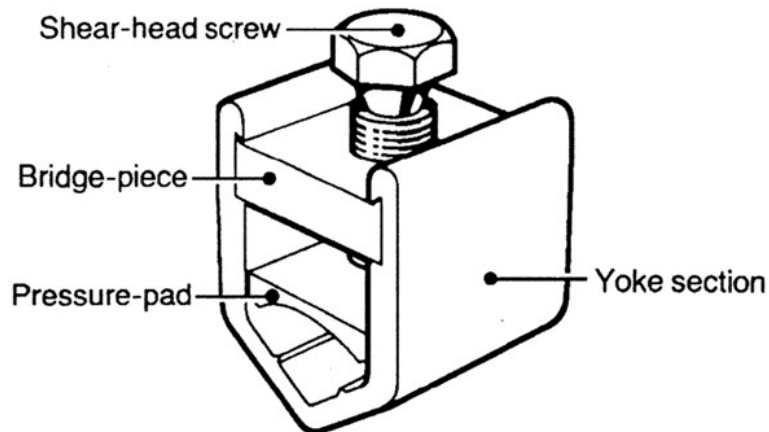

Principle Application

Stranded service connections from stranded sector shaped mains conductors.

Range

Connector Ref <i>(Part Number)</i>	Core c.s.a. (mm ²)		
	Mains		Service
	Min.	Max.	Max
US1 <i>(51801-40)</i>	50	95	35
US2 <i>(2466-297)</i>	120	185	50
US3 <i>(51809-43)</i>	185	300	50
US4 <i>(51801-83)</i>	50	95	50

The Sicame US range of service branch connectors has been designed to connect stranded circular or sector shaped services to three or four core stranded sector shaped mains conductors in the ranges specified above.

Ease of fitting and simplicity of use were fundamental objectives adopted in the design of this range of connectors, and the Sicame shear head screw principle ensures that a reliable and consistent connection is achieved without the need for specialised tooling.

**US1, US2,
US3 & US4
Connectors**

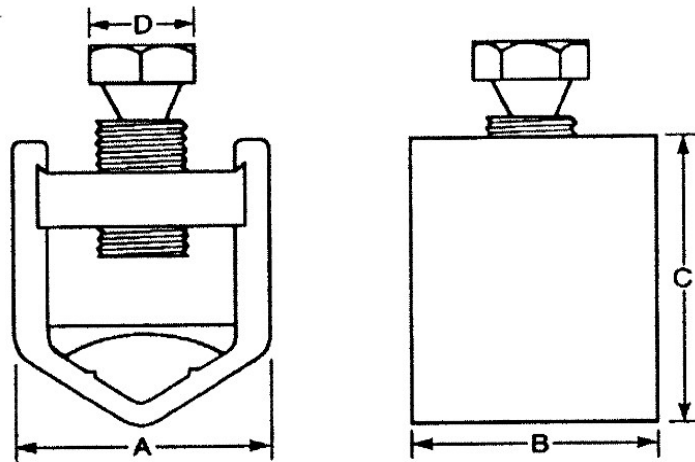

Connector Ref <i>(Part Number)</i>	Dimensions (mm)			
	A	B	C	D
US1 <i>(51801-40)</i>	28	25	40	17
US2 <i>(2466-297)</i>	31	30	44	17
US3 <i>(51809-43)</i>	42	40	53	17
US4 <i>(51801-83)</i>	28	25	40	17

Material

Body: Aluminium Alloy

Screws: Aluminium Alloy

Test Specification:

Engineering recommendation C79.

Test report numbers –US1/C95XC35, US2/AL50X/2C35, US3/A300X/2C35, US3/C300X/2C35.

Fitting Instructions:

1. Separate the main cable cores sufficiently to allow the yoke section to be fitted around the conductor and strip the insulation from the core equal to the connector length plus 5mm. Cut the service conductor to length, strip the insulation to suit, then separate the individual strands and splay out to form a single layer that will spread out over the back radius of the main conductor.
2. Loosely assemble the connector around the cores by inserting the bridge piece and locating the pressure pad over the splayed out service strands, then tightening the shear head screw until positive location is achieved. Check for even distribution of the service strands then finally tighten the screw until the head shears.
3. If copper conductors are to be jointed they should be wrapped in brass gauze. In case of a copper service conductor being jointed onto a stranded aluminium main, care must be taken to ensure that the individual strands of the service conductor are spread out in the fashion described above within the wrap of the brass gauze. All conductors must be thoroughly abraded.